

DESPIECE BOMBA- MEMBRANAS PPS 100

BERTOLINI
pumps

PARA MÁS CONSULTAS O DUDAS:
LLÁMANOS: 96 545 53 91 - 96 661 52 44
MÁNDANOS UN WHATSAPP 609 87 53 95
O UN E-MAIL : INFO@BLASCOMOTOR.COM

WWW.AGRICOLABLASCOONLINE.COM

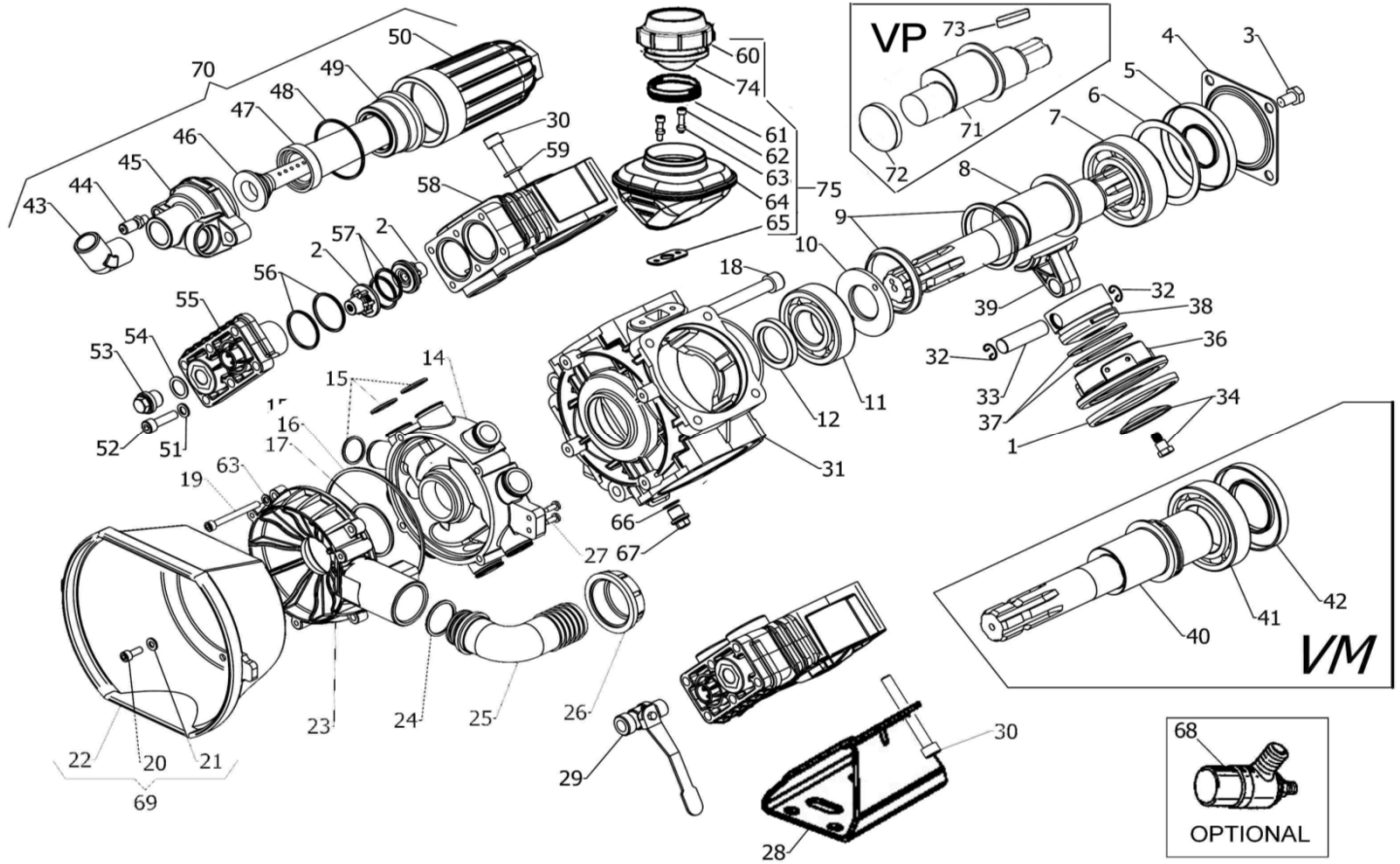

POS.	CODICE PART NO. REF.	DENOMINAZIONE - DESCRIPTION - DESCRIPTION	Q.TY
1	23.0011.31.2	PISTONS DIAPHRAGM BUNA-N	4
1	23.0011.33.2	PISTONS DIAPHRAGM VITON (OPT.)	4
1	23.0011.00.2	PISTONS DIAPHRAGM DESMOPAN (OPT.)	4
2	23.9805.97.3	VALVE ASSY	8
3	86.3187.00.2	SCREW M10X18 UNI5739	4
4	17.0013.61.2	COVER	1
5	80.2190.10.2	OIL SEAL 40X90X10	1
6	17.0024.76.2	PACKING SPACER	1
7	81.2913.00.2	BEARING 45X90X23	1
8	36.0017.26.2	CRANKSHAFT TYPE VD (1 3/8 M-M)	1
9	98.0047.76.2	CONROD RING	2
10	36.0019.61.2	CONROD HOLDING RING	1
11	81.2867.00.2	BEARING 35X80X21	1
12	80.2143.10.2	OIL SEAL 35X52X7	1
14	36.0008.32.2	MANIFOLD	1
15	80.3204.50.2	O-RING DIA. 2.62X23.81 (KIT VITON)	9
16	80.3291.25.2	O-RING DIA. 3.53X123.4	1
16	80.3291.30.2	O-RING DIA. 3.53X123.4 (KIT VITON)	1
17	80.3270.00.2	O-RING DIA. 3.53X49.2	1
17	80.3270.50.2	O-RING DIA. 3.53X49.2 (KIT VITON)	1
18	86.4120.00.2	SCREW TCEI M12x110 UNI5931	1
19	86.2415.50.2	SCREW TCEI M6X60 UNI5931	4
20	86.1846.00.2	SCREW TCTC 5.5x16 (OPTIONAL)	3
21	84.3560.00.2	WASHER DIA. 5,5x15x1,6 (OPTIONAL)	3
22	31.1466.32.2	PLAIN SAFETY CONE OPTIONAL)	1
23	36.0009.32.2	MANIFOLD COVER	1
24	80.3219.10.2	O-RING DIA. 3,0X30	1
25	84.0591.00.2	90° ELBOW CONNECTOR DIA. 40-1,57"	1
26	82.0070.00.2	WING NUT G.1"1/2	1
27	86.1843.00.2	SCREW D.4.8X16	2
28	36.0033.61.2	FOOT	2
29	84.5544.10.2	LEFT TAP	2
30	86.3590.00.2	SCREW TCEI M10X80 UNI5931	16
31	36.0001.09.2	CRANKCASE	1
32	80.0021.00.2	SNAP RING	8
33	85.2007.00.2	PISTON PIN 15 X 54	4
34	23.0055.97.3	KIT DISK INOX+SCREW	4
36	23.0038.01.2	PISTONS SLEEVE	4
37	81.8514.00.2	PISTONS RING DIA. .62X2,5	8
38	23.0040.09.2	PISTONS DIA. .62	4

POS.	CODICE PART NO. REF.	DENOMINAZIONE - DESCRIPTION - DESCRIPTION	Q.TY
39	36.0015.11.2	CONROD	4
40	36.0020.26.2	CRANSHAFT TYPE VM (1 3/8 M-F)	1
41	81.2969.00.2	BALL BEARING 6210	1
42	80.2236.00.2	OIL SEAL 50X90X10	1
43	83.5063.28.2	60° ELBOW CONNECTOR G.3/4 M/M	1
44	86.1605.00.2	AIR VALVE	1
45	36.0010.28.2	BALLASTER BOARD	1
46	36.0013.32.2	INSIDE TUBE BALLASTER	1
47	36.0007.31.2	BALLASTER DIAPHRAGM	1
48	80.3210.00.2	O-RING DIA. 2.62X56,82	1
48	80.3210.10.2	O-RING DIA. 2.62X56,82 (KIT VITON)	1
49	36.0014.09.2	DIAPHRAGM SPACER BALLASTER	1
50	36.0011.09.2	TOP BALLASTER	1
51	84.3685.00.2	WASHER DIA. 8,2X15X1,5 UNI1750	24
52	86.2730.00.2	SCREW TCEI M8X30 UNI5931	24
53	85.2579.00.2	CAP G.3/8	2
54	80.3065.00.2	O-RING DIA. D.1,78X14	2
54	80.3065.10.2	O-RING DIA. D.1,78X14 (KIT VITON)	2
55	36.0003.32.2	VALVE COVER	4
56	80.3219.20.2	O-RING DIA. 3,0x35	8
56	80.3219.50.2	O-RING DIA. 3,0x35 (KIT VITON)	8
57	80.3207.00.2	O-RING DIA. 2.62X29,82	8
57	80.3207.50.2	O-RING DIA. 2.62X29,82 (KIT VITON)	8
58	36.0002.09.2	HEAD	4
59	84.3801.00.2	WASHER DIA. 10,5X18X2 UNI1750	8
60	28.0144.32.2	FILLER COVER	1
61	14.0116.32.2	SPACER	1
62	86.2168.00.2	SCREW TCEI M6X22 UNI5931	2
63	84.3585.00.2	WASHER DIA. 6 UNI6592	6
64	40.9801.97.3	ASSEMBLY OIL FILLER	1
65	14.0017.72.2	OIL FILLER GASKET	1
66	82.4079.00.2	GASKET D.13,2X17X1	1
67	85.2543.50.2	CAP G.1/4X9	1
68	24.3040.97.3	SECURITY VALVE 40 BAR(OPTIONAL)	1
69	36.9814.97.3	PLAIN SAFETY CONE KIT	1
70	36.9810.97.3	BALLASTER KIT	1
71	36.0036.26.2	CRANKSHAFT TYPE "VP" (D.35 M)	1
72	80.2099.60.2	CAP	1
73	80.6578.20.2	TAB 10X8X35 UNI 6604	1
74	41.0017.31.2	DIAPHRAGM OIL FILLER	1
75	40.9809.97.3	OIL FILLER KIT	1